

**Modular Cooking Range Line  
 thermaline 80 - Electric Free-cooking  
 Top on Warming Cabinet with  
 Backsplash H=700**

ITEM # \_\_\_\_\_

MODEL # \_\_\_\_\_

NAME # \_\_\_\_\_

SIS # \_\_\_\_\_

AIA # \_\_\_\_\_

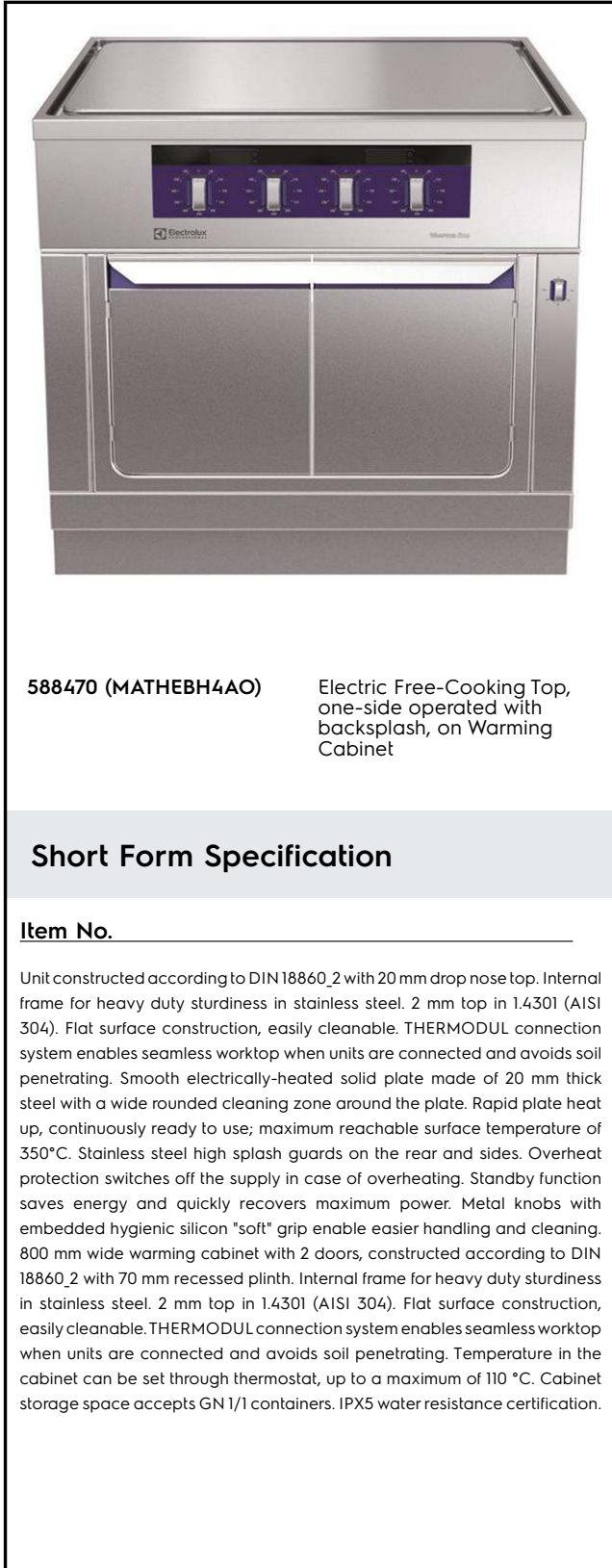

**588470 (MATHEBH4AO)** Electric Free-Cooking Top, one-side operated with backsplash, on Warming Cabinet

### Short Form Specification

**Item No.** \_\_\_\_\_

Unit constructed according to DIN 18860\_2 with 20 mm drop nose top. Internal frame for heavy duty sturdiness in stainless steel. 2 mm top in 1.4301 (AISI 304). Flat surface construction, easily cleanable. THERMODUL connection system enables seamless worktop when units are connected and avoids soil penetrating. Smooth electrically-heated solid plate made of 20 mm thick steel with a wide rounded cleaning zone around the plate. Rapid plate heat up, continuously ready to use; maximum reachable surface temperature of 350°C. Stainless steel high splash guards on the rear and sides. Overheat protection switches off the supply in case of overheating. Standby function saves energy and quickly recovers maximum power. Metal knobs with embedded hygienic silicon "soft" grip enable easier handling and cleaning. 800 mm wide warming cabinet with 2 doors, constructed according to DIN 18860\_2 with 70 mm recessed plinth. Internal frame for heavy duty sturdiness in stainless steel. 2 mm top in 1.4301 (AISI 304). Flat surface construction, easily cleanable. THERMODUL connection system enables seamless worktop when units are connected and avoids soil penetrating. Temperature in the cabinet can be set through thermostat, up to a maximum of 110 °C. Cabinet storage space accepts GN 1/1 containers. IPX5 water resistance certification.

### Main Features

- Rapid heat up of the plate and continuously ready for use.
- Overheat protection: a temperature sensor switches off the supply in case of overheating.
- Stainless steel high splash guards on the rear and sides of cooking surface.
- Wide rounded cleaning zone around the plates for easier cleaning.
- All major components may be easily accessed from the front.
- THERMODUL connection system creates a seamless work top when units are connected to each other thus avoiding soil penetrating vital components and facilitating the removal of units in case of replacement or service.
- Metal knobs with embedded hygienic silicon "soft" grip for easier handling and cleaning. The special design of the controls prevent infiltration of liquids or soil into vital components.
- Large visible digital display manufactured in tempered glass to resist heat and chemicals, showing temperatures or power settings. The display also shows on/off status of the appliance and on/off status of the heating elements.
- Cooking plate and base joint profile guarantee against soil infiltration.
- Surface temperature up to 350°C
- Unit constructed according to DIN 18860\_2 with 70 mm recessed plinth.
- For direct and indirect cooking.
- Temperature in the cupboard can be set through a thermostat to suit different requirements. The maximum temperature is 110°C.

### Construction

- 2 mm top in 1.4301 (AISI 304).
- Unit constructed according to DIN 18860\_2 with 20 mm drop nose top and 70 mm recessed plinth.
- Flat surface construction with minimal hidden areas to easily clean all surfaces
- IPX5 water resistance certification.
- Storage space in the base of the appliance accepts GN1/1 containers.
- Unit constructed according to DIN 18860\_2 with 20 mm drop nose top.
- Cooking surface is an electrically heated solid plate made from 20 mm thick stainless steel AISI 316 - DIN 1.4404.
- 2mm thick top in stainless steel AISI 304 - DIN 1.4301.

**APPROVAL:** \_\_\_\_\_

- Internal frame for heavy duty sturdiness in stainless steel.

## Sustainability



- Standby function for energy saving and fast recovery of maximum power.

## Optional Accessories

- Connecting rail kit for appliances with backsplash, 800mm PNC 912497
- Portioning shelf, 800mm width PNC 912526
- Portioning shelf, 800mm width PNC 912556
- Folding shelf, 300x800mm PNC 912577
- Folding shelf, 400x800mm PNC 912578
- Fixed side shelf, 200x800mm PNC 912583
- Fixed side shelf, 300x800mm PNC 912584
- Fixed side shelf, 400x800mm PNC 912585
- Stainless steel front kicking strip, 800mm width PNC 912634
- Stainless steel side kicking strip left and right, against the wall, 800mm width PNC 912658
- Stainless steel side kicking strip left and right, back-to-back, 1610mm width PNC 912661
- Stainless steel plinth, against wall, 800mm width PNC 912844
- Connecting rail kit for appliances with backsplash: modular 80 (on the left), ProThermetic tilting (on the right), ProThermetic stationary (on the left) to ProThermetic tilting (on the right) PNC 912977
- Connecting rail kit for appliances with backsplash: modular 80 (on the right), ProThermetic tilting (on the left), ProThermetic stationary (on the right) to ProThermetic tilting (on the left) PNC 912978
- Back panel, 800x700mm, for units with backsplash PNC 913013
- Stainless steel panel, 800x700mm, against wall, left side PNC 913093
- Stainless steel panel, 800x700mm, against the wall, right side PNC 913097
- Endrail kit, flush-fitting, with backsplash, left PNC 913113
- Endrail kit, flush-fitting, with backsplash, right PNC 913114
- Scraper for smooth plates PNC 913119
- Endrail kit (12.5mm) for thermaline 80 units with backsplash, left PNC 913204
- Endrail kit (12.5mm) for thermaline 80 units with backsplash, right PNC 913205
- U-clamping rail for back-to-back installations with backsplash PNC 913226
- Insert profile D=800mm PNC 913230
- Perforated shelf for warming cabinets and cupboard bases (one-side operated TL80-85-90 and two-side operated for TL80) PNC 913234
- Energy optimizer kit 32A - factory fitted PNC 913247

- Side reinforced panel only in combination with side shelf, for against the wall installations, left PNC 913263
- Side reinforced panel only in combination with side shelf, for against the wall installations, right PNC 913265
- Shelf fixation for TL80-85-90 one-side operated, TL80 two-side operated PNC 913281
- Filter W=800mm PNC 913665
- Stainless steel dividing panel, 800x700mm, (it should only be used between Electrolux Professional thermaline Modular 80 and thermaline C80) PNC 913668
- Stainless steel side panel, 800x700mm, flush-fitting (it should only be used against the wall, against a niche and in between Electrolux Professional thermaline and ProThermetic appliances and external appliances - provided that these have at least the same dimensions) PNC 913684

## Recommended Detergents

- C41 HI-TEMP RAPID DEGREASER, 1 pack of six 1 lt. bottles (trigger incl.) PNC 0S2292

Front

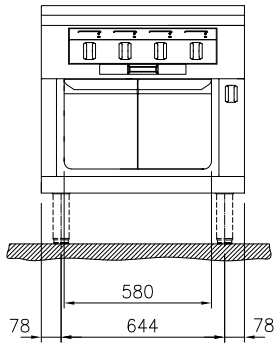

Side

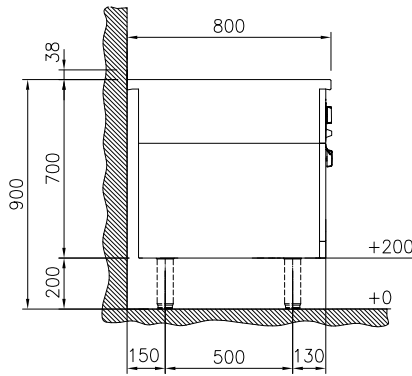

EI = Electrical inlet (power)  
 EQ = Equipotential screw

Top

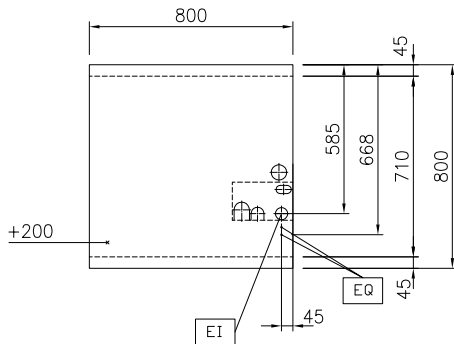
**Electric**
**Supply voltage:**

588470 (MATHEBH4AO) 400 V/3N ph/50/60 Hz

**Electrical power max.:**

14.3 kW

**Key Information:**
**Configuration:** On Oven, One-Side Operated

**Front Plates Power:** 3 - 3 kW

**Back Plates Power:** 3 - 3 kW

**Solid top usable surface (width):** 670 mm

**Solid top usable surface (depth):** 650 mm

**External dimensions, Width:** 800 mm

**External dimensions, Depth:** 800 mm

**External dimensions, Height:** 700 mm

**Storage Cavity Dimensions (width):**
**Storage Cavity Dimensions (height):**
**Storage Cavity Dimensions (depth):** 0 mm

**Net weight:** 143 kg

**Sustainability**
**Current consumption:** 30.5 Amps